

*Steel Cattle Hay Rack
Feeder Plans Book
8 Foot - 2400mm*

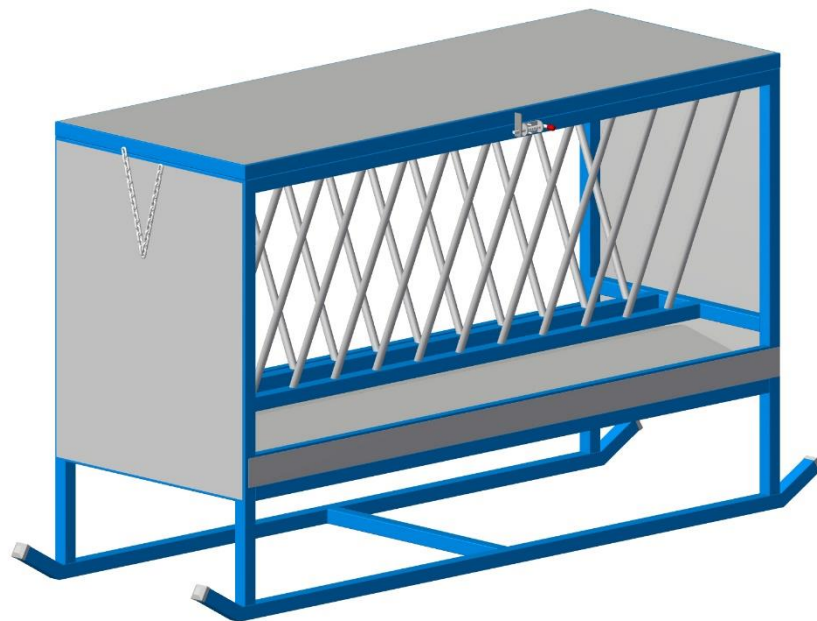

Kurraglen Industries
PO Box 215
Gulgong, NSW, 2852
Australia

<https://www.kurraglenindustries.com.au>

sales@kurraglenindustries.com.au

<https://www.facebook.com/kurraglen/>



Cattle Hay Feeder 2400mm (8 Foot)

The cattle hay feeder is an essential part of the farm equipment inventory. It allows the hay to be available to your cattle as they require it, keeps it off the ground so that the cattle don't spoil it and with the addition of the roof, minimises the chance of the hay getting wet.

Tools required include a welder, either stick or mig, G clamps or welding clamps, tape measure, angle grinder for cutting and cleaning up welds, electric drill and a square. You may buy lengths of steel and cut it to the correct sizes if you have either an angle grinder or electric bandsaw or you may choose to have the steel cut for you from a local steel supplier. One thing that will make your job a lot easier is to construct a pair of welding trestles as shown on our website (www.kurraglenindustries.com.au). The plans for the welding trestles are free. You will also need access to a steel sheet folder for the tray unless you make them in separate sections. A steel sheet guillotine is also desirable as the cut edge is cleaner than using an angle grinder with a cutting disc.

To make the best use out of your lengths of steel, we have a free-to-use Cutting List Optimiser on our website. Visit <https://www.kurraglenindustries.com.au/linear-cutting-list-calculator.htm>

The following steel and materials are required to build the 8 foot hay rack:

50x50x2.0 SHS - Approx. 5 x 8 metre lengths	50x50 square caps – 4 (for the skids)
30x30x2.0 SHS – 4.8 metres	Rivets or self-drilling tek screws
Sheet - 1.5mm thick. 3 x sheets 1220x2440mm	Set of hinges - 1
32x5 flat bar - 80mm	12mm spring bolt - 1
20nb light wall pipe – 4 x 6.5 metre lengths	Chain 5 or 6mm diameter. Approx. 800mm long

Cutting List for the 8 foot hay feeder				
Item No	Quantity	Material	Size (mm)	Notes
1	4	50x50x2.0 SHS	1450	45 degree mitre one end
2	2	50x50x2.0 SHS	2500	15 degree mitre both ends
3	4	50x50x2.0 SHS	200	15 degree mitre one end
4	2	50x50x2.0 SHS	2460	45 degree mitre one end
4A	2	50x50x2.0 SHS	2360	
5	2	50x50x2.0 SHS	820	
6	1	50x50x2.0 SHS	820	
7	2	50x50x2.0 SHS	820	
8	2	50x50x2.0 SHS	820	
9	2	50x50x2.0 SHS	2360	
9A	2	30x30x2.0 SHS	2360	
10	2	50x50x2.0 SHS	2460	45 degree mitre both ends
11	2	50x50x2.0 SHS	920	45 degree mitre both ends
12	1	50x50x2.0 SHS	820	

1. Begin by cutting all of the steel as indicated in the cutting list. Label each with the item number on it using a marking pen and set aside. Take note of the mitre cuts for the SHS to ensure that they are cut the correct way.

2. Tack weld the front frame as shown in diagram 1. Check that the frame is square and fully weld. Repeat for the rear frame.

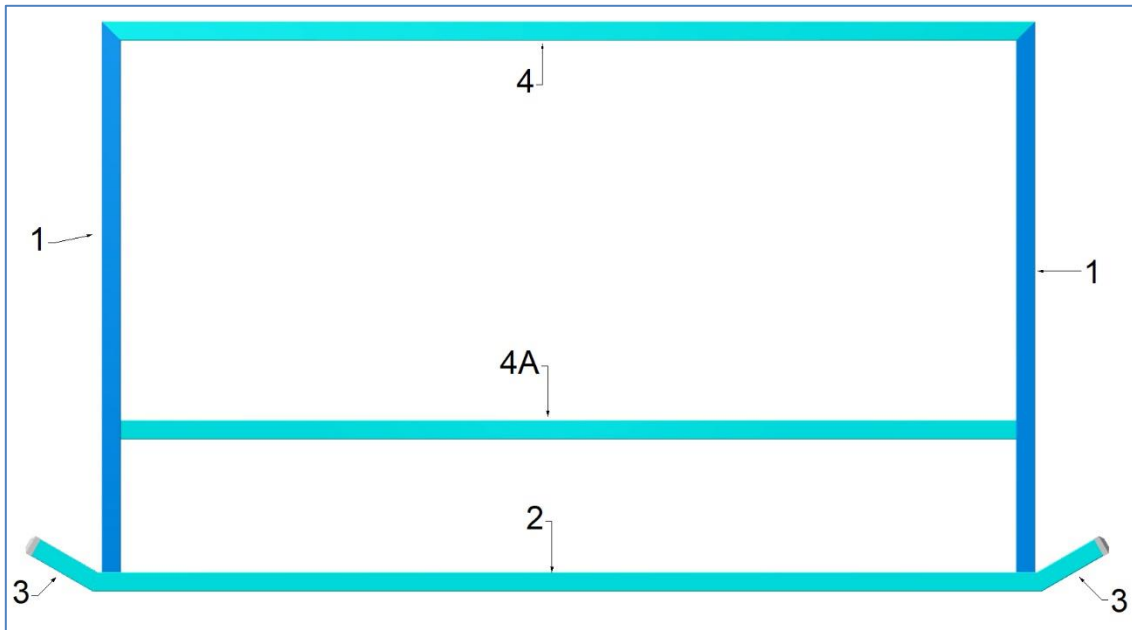

Diagram 1

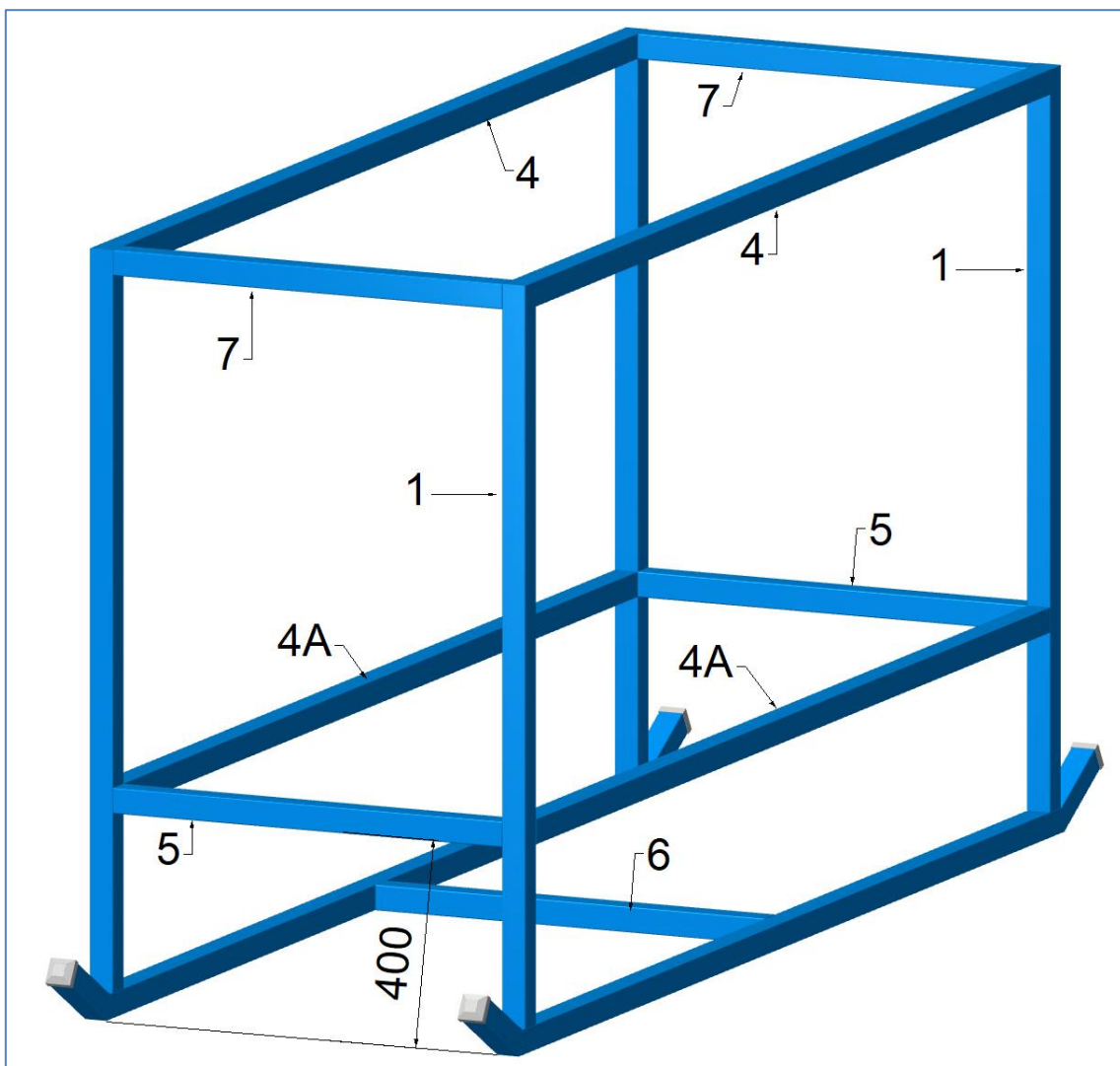

Diagram 2

3. Secure the front and rear frame in an upright position and tack weld items 5, 6 and 7 as shown in diagram 2. The lower edge of items 5 should be 400mm up from the ground and item 6 should be installed in the centre of the front and rear frames.
4. Cut and fold sheet for the tray as shown in diagram 3. The length of the sheet is 2440mm.

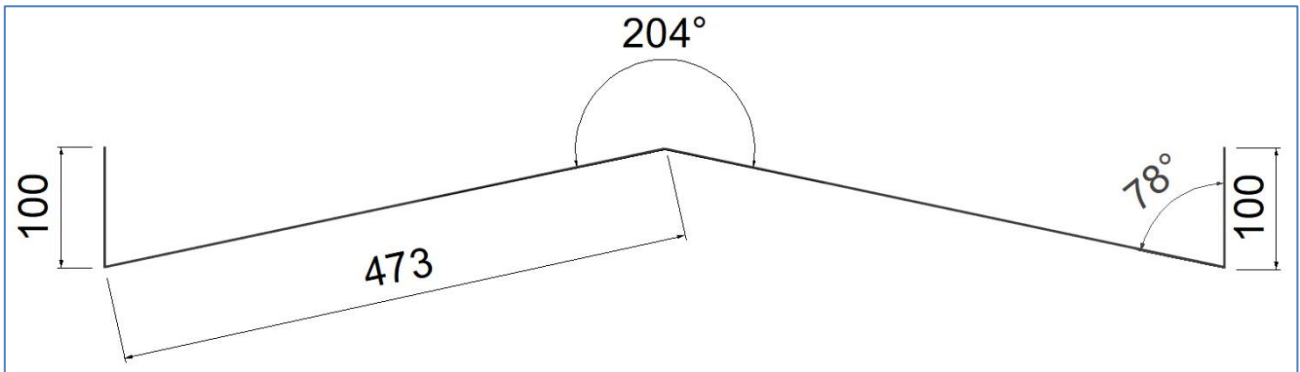

Diagram 3

5. Cut notches in the corners of the sheet approximately 55mm x 55mm square. These are to fit around items 1.

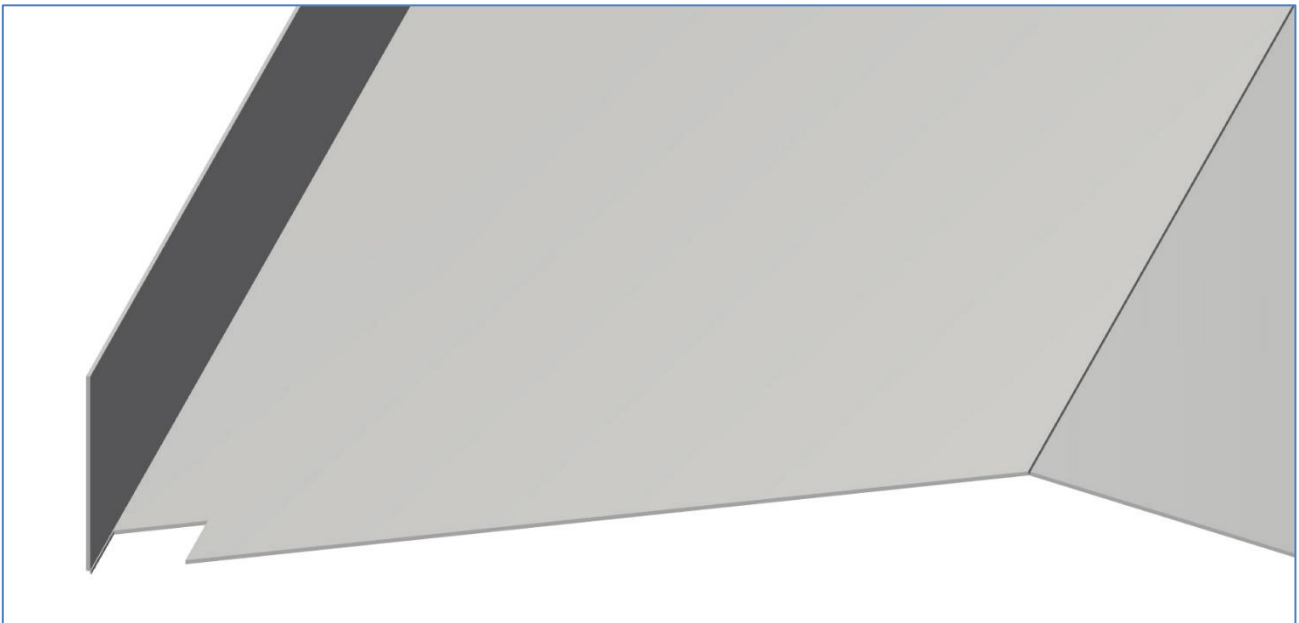

Diagram 4

6. Install the tray sheet into the frame and secure with self-drilling tek screws through the front and rear of the sheet into items 1. Refer to diagram 5.
7. Weld items 8 in place.
8. Weld items 9 in position. These should be located in the centre of items 8 and spaced 150mm apart. Weld items 9A in place. Items 9A should be a couple of millimetres above the top edge of the tray sheet. Refer to diagram 5.

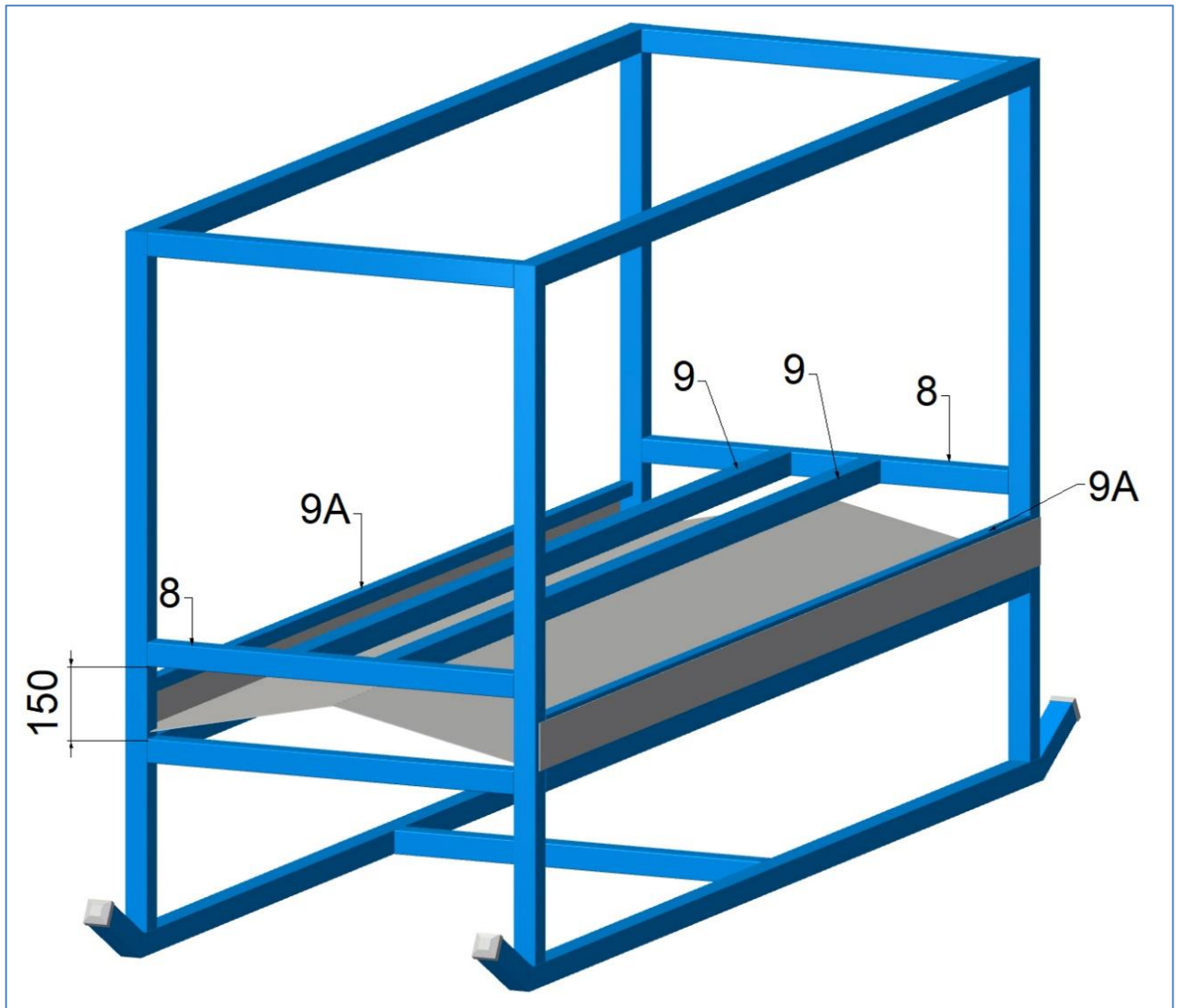

Diagram 5

9. Cut one of the pipe bars to size. Note that the overall length of the pipe is 879mm. Refer to diagram 6. Check that it is the correct length and angle by trial fitting it before proceeding to cut the balance. Refer to diagram 6.

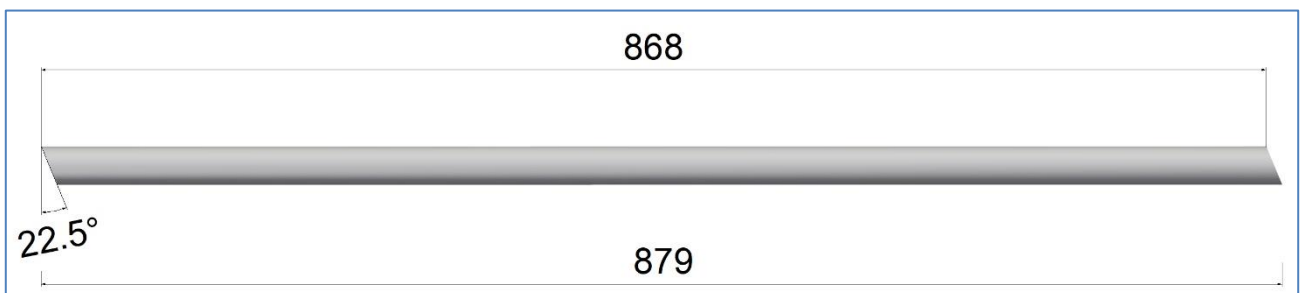

Diagram 6

10. Weld the pipe bars in place as shown in diagram 7. The pipes should be spaced approximately 163mm apart.

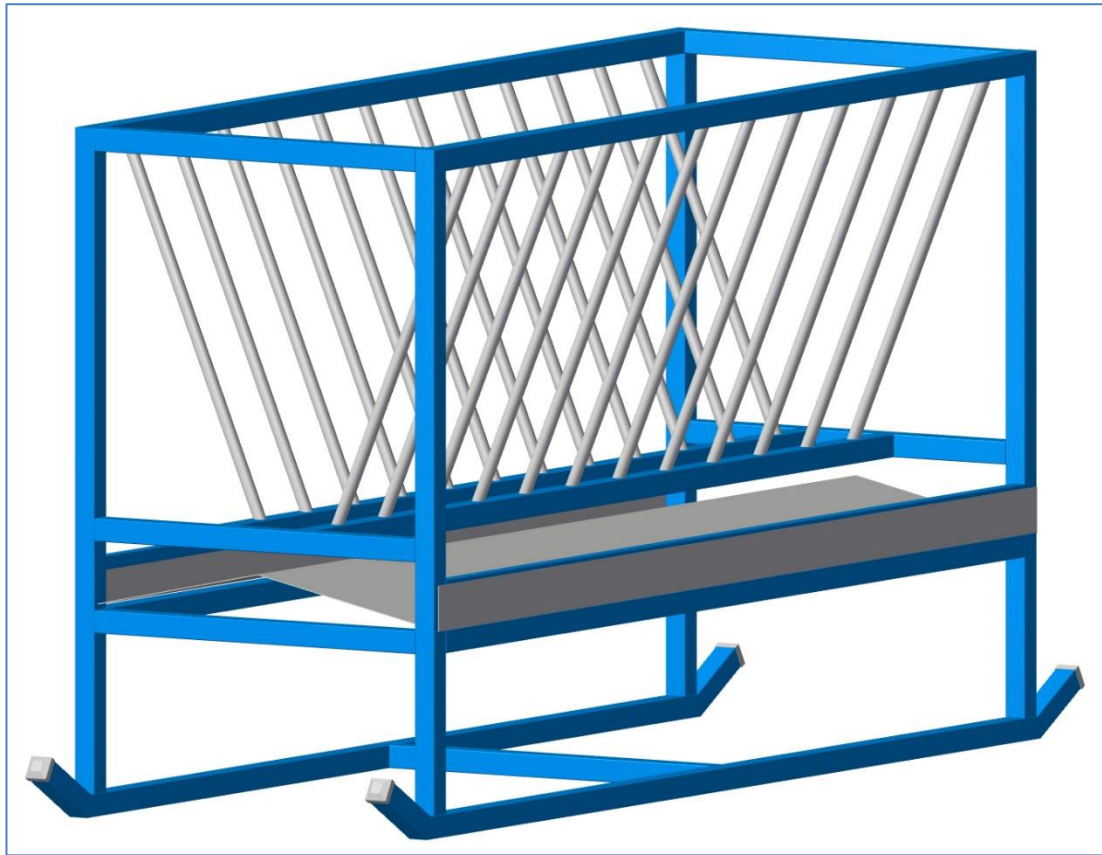

Diagram 7

11. Cut the end sheets to size. These should be 1080mm x 900mm. Secure these in place using self-drilling tek screws or rivets. Refer to diagram 8.

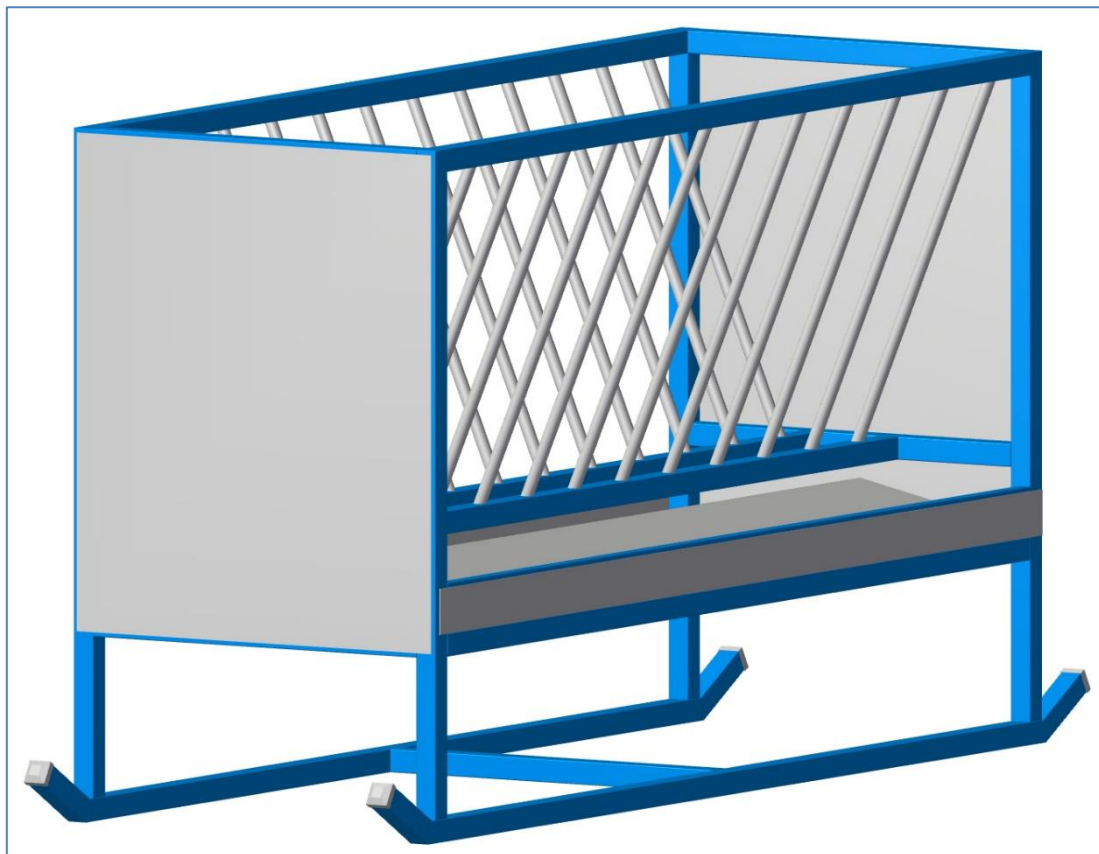

Diagram 8

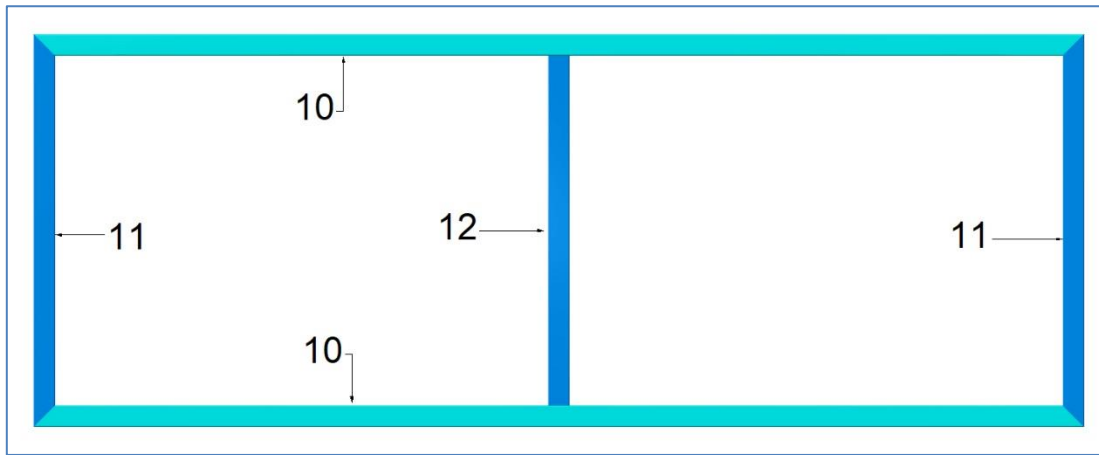

Diagram 9

12. Tack weld items 10,11 and 12 together to form the roof frame. Recheck that the frame is square and fully weld as shown in diagram 9.
13. Cut the sheet for the roof which should be 2440mm x 900mm. Secure the sheet to the roof frame using pop rivets or self-drilling tek screws.

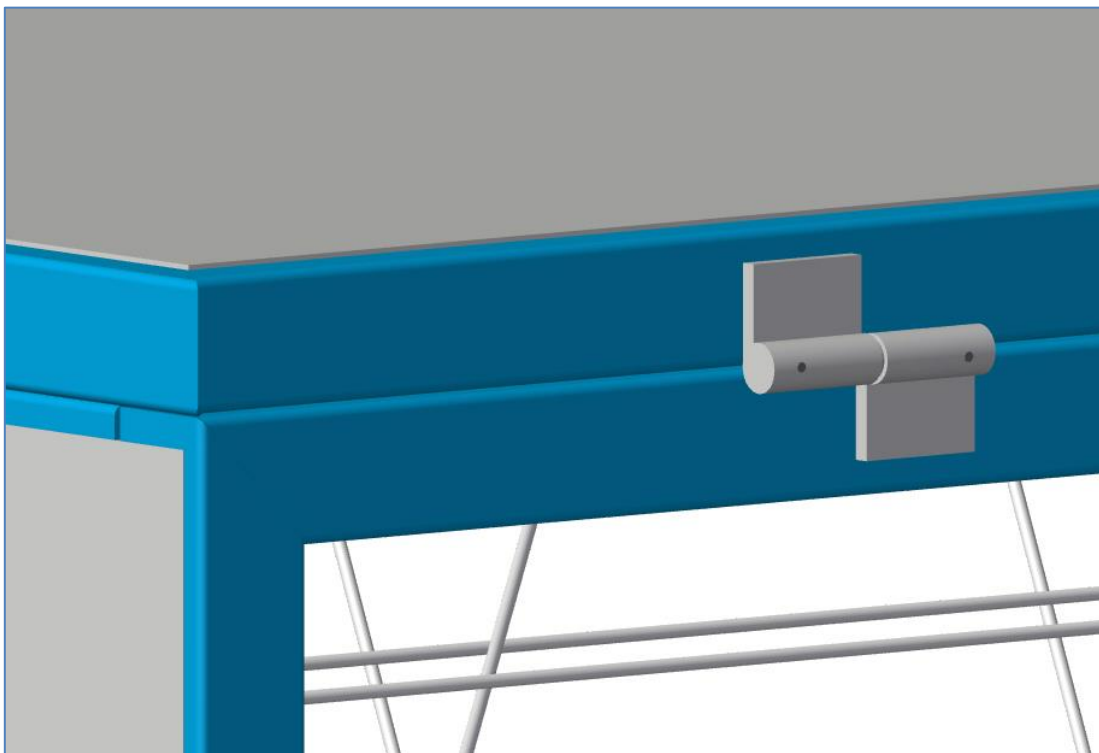

Diagram 10

14. Install the hinges as shown in diagram 10. It is a good idea to make sure that the hinges that you use will not allow the roof to slide sideways and come off the hinge pins. The hinges shown are normally available in a left hand and a right hand version and are ideal for this purpose.

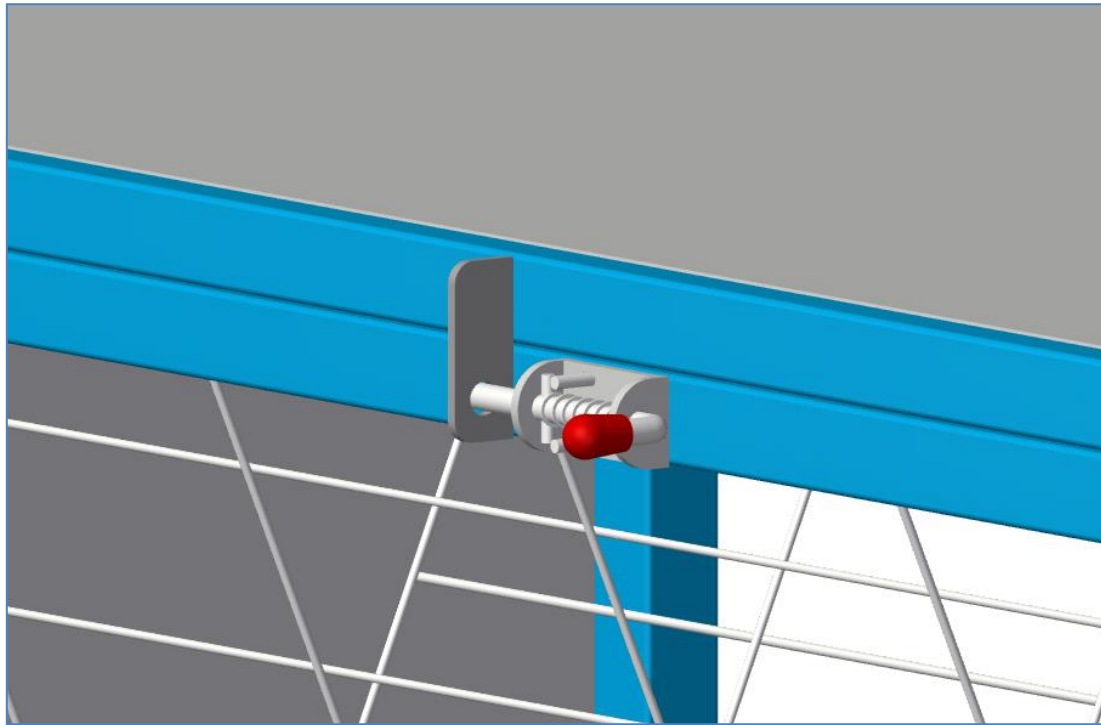

Diagram 11

15. Cut a piece of 32x5mm flat bar 80mm long and drill a 14mm hole approximately 20mm up from the bottom for the spring bolt pin.
16. Weld the flat bar and spring bolt in place as shown in diagram 11. The flat bar is welded to the roof frame whilst the spring bolt is welded to the hay rack frame.
17. Cut a piece of galvanised chain approximately 800mm long and weld one end to item 7 of the hay rack frame and the other end to item 11 of the roof frame. This is so that when the roof is open, it will not fall all of the way back.
18. Clean any welds using a grinding disc or flap disc and paint as required.

Proud of your project? Email us the photos of your equipment or yards that you have made from our books and we will put them up on our website for others to admire. You can even be in the photo if you would like to be. Be sure that you include your name, where you are from and a brief description. Please make sure that the photos are of good quality, in jpg (jpeg) or png format, at least 72 dpi and at least 900 pixels by 600 pixels. Email your photos to: projects@kurraglenindustries.com.au